



OCST Series

FEATURES

- Fast resolution switching
- 35mm 5 digits LED display
- Idle mode to maximize the battery life
- HOLD function
- Tare In / Tare Out
- Unit switch: kg / lb
- Auto overload alarm at 100%F.S. +9e
- Auto power-off function

Model	OCST
Type	Compact
Accuracy Class	OIML III
Enclosure	Die-casting Aluminum
Display	30mm LED
Capacity Available	2 / 4 / 6 / 10 Klb
Battery Life	80 Hours
High Quality Load Receptor	Alloy Steel
Shackle	Fixed
Hook	Rotatable
High Capacity Rechargeable Battery	Yes 6V/4Ah
Infrared Remote Control	Yes

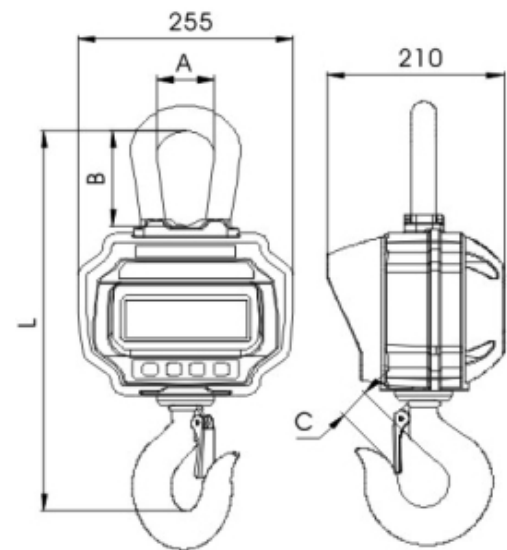

Rated Capacity	Division	A	B	C	L	N.W.
1t / 2Klb	0.5kg / 1 lb	68mm / 2.68"	112mm / 4.41"	40mm / 1.57"	420mm / 16.54"	11.0kg / 24.25 lb
2t / 4Klb	1kg / 2 lb	68mm / 2.68"	112mm / 4.41"	40mm / 1.57"	420mm / 16.54"	11.0kg / 24.25 lb
3t / 6Klb	1kg / 2 lb	68mm / 2.68"	112mm / 4.41"	40mm / 1.57"	420mm / 16.54"	11.0kg / 24.25 lb
5t / 10Klb	2kg / 5 lb	68mm / 2.68"	112mm / 4.41"	45mm / 1.77"	450mm / 17.72"	12.5 kg / 27.56 lb

*Dimensions and specifications are subject to change without notice.